

Analysis on CNC Machining and Manufacturing Technology of Mechanical Molds

Wang Zhenhua, Yin Haifang

Shandong Huayu University of Technology, Shandong, China, 253034

Keywords: Mechanical mold; CNC machining; Manufacturing technology

Abstract: In recent years, with the science and technology development, CNC machining and manufacturing technology of mechanical mold has also had a great development. Higher requirements are put forward for mechanical molds, such as structure complexity, profile complexity, materials hardness and precision requirements. In the mold manufacture, the mechanical mold numerical control processing technology has the extremely important function. This paper analysis the CNC machining and manufacturing technology of mechanical molds, and then analyzes the application method in manufacturing. Finally, this paper analyses the development trend of CNC machining technology for mechanical die manufacturing. It is expected that through the study of this paper, the application of CNC machining technology in the mold manufacturing industry can be promoted.

1. Introduction

At present, mechanical mold processing mainly includes spark wire cutting, spark machining, turning processing, milling and washing processing, grinding processing, CNC processing and other links. Each processing link has a clear processing task and unique processing function, each link cannot replace each other. From the point of the mechanical mold' structure and production mode, the differences between various mechanical mold is obvious. The mechanical mold basically belongs to the single small batch production. This requests the manufacture technology diversification, we must pay attention to the mold manufacture innovation technology. From the point of mechanical mold products, mechanical mold is complex structure, high machining precision requirements, complex CNC machining data programming. From the point of mechanical mold delivery, the number is determined by the customer, the enterprise processing ability determines the mechanical mold time. So, there is randomness on the production scale and processing time.

2. The Advantages on CNC Machining Technology of Mechanical Mould

2.1 The high precision

Precision is the key factor to measure the quality and efficiency of CNC machining. In NC machining, we must analysis the geometric precision of machining strictly according to the requirement. Only in this way, we can promote the effective improvement of machining accuracy, and then avoid the appearance of various machining errors.

2.2 Shorten processing time

When CNC machine tools processing parts, the operator must first edit the program, and then input CNC machine tools, and finally install the required machining tools. After completing these steps, we can use the CNC machine tool to process the parts. The biggest characteristic of CNC is that it reduces the number of cutting tool loading, unloading and adjustment, and it reduces the machining error which caused by non-standard machining behavior. CNC has greatly improved the machining efficiency of parts processing. In addition, compared with traditional machine tools, CNC machine tool structure rigidity is larger, which is helpful for improving the cutting effect. So,

it reduces the time needed for parts processing.

2.3 Reduce labor intensity

Compared with traditional machine tools, CNC machine tool has realized the numerical control operation in the entire processing process. In the actual operation process, the operator only needs to complete the corresponding processing procedures according to the processing requirements. This not only effectively reduced the working intensity of the operator, but also relatively low requirements for skilled workers.

2.4 Reduce operating frequency

When the mold batch processing production, using the CNC machine bed processing has become the most important choice. CNC machine tools should choose the most appropriate tool change, so that it can shorten a lot of auxiliary time, reduce the wear of the machine tool, reduce maintenance costs. Compared with general general machine tools, CNC machine tools have detailed detailed steps, such as tool changing frequency, processing line, fixture choosing, tool installation and sequence. In the process of machining mold, CNC improves the working efficiency of machine tools.

2.5 Increase economic efficiency

CNC machine tools are controlled by a computer program, and in the program control it can automatically complete the program. So, CNC can perform some repetitive operations without heavy and complex operations. CNC can continuously and automatically complete parts processing with the processing accuracy, which makes the rate of defective products greatly reduced. At the same time, the numerical control machine tool processing omitted many special tooling links, Such as manual production by mold, sample, drilling template, etc. CNC makes the production cost further reduced, which has produced huge economic benefits.

3. CNC Machining and Manufacturing Technology of Mechanical Molds

3.1 The application of NC edm technology

CNC edm technology is widely used in machining machine dies. Compared with the traditional method, this technique can greatly reduce the cost requirement. CNC edm technology can not only meet the processing accuracy, but also improve the quality of processing. It reduces the cycle of mold processing, and further driving the vigorous development of machinery. CNC edm technology is often used in rapid prototyping, which has high precision and low programming difficulty. Compared with the insert cavity, special material mold, micro complex shape, special groove, insert and so on, CNC edm technology is relatively low. In various straight-wall die processing, we will mainly use the wire cutting technology, such as injection mold slider and insert block, stamping die concave punch, electrode in the edm. The schematic diagram of NC edm machining is shown as the Figure 1.

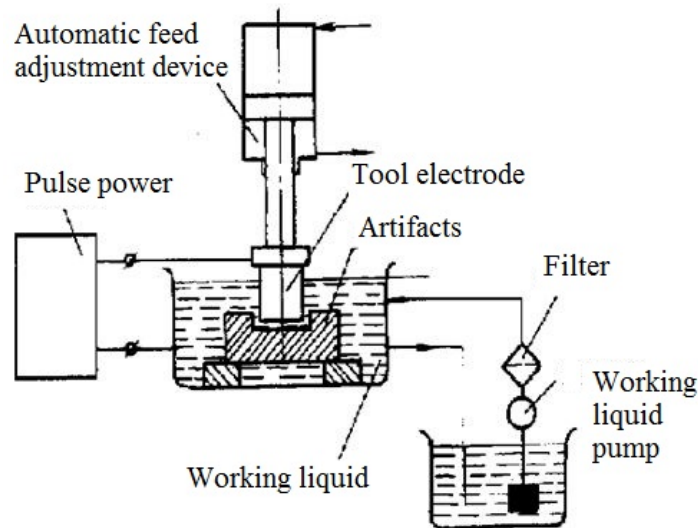

Figure 1: Schematic diagram of NC edm machining

3.2 The application of NC milling technology

CNC milling technology is one of the most common CNC machining method, it is a relatively mature technology. Many molds structure are planar structure, and generally composed with surface, concave and convex, which requires CNC milling technology. CNC milling technology can be processed with curved surface, the more complex shape mold. For example, mold casting mould, injection mould and electrode can be used in edm. At the same time, it can also be used CNC milling technology. In recent years, with the rapid development of CNC machining technology, mold manufacturing is often used in large data milling machining center. The schematic diagram of NC milling machining is shown as the Figure 2.

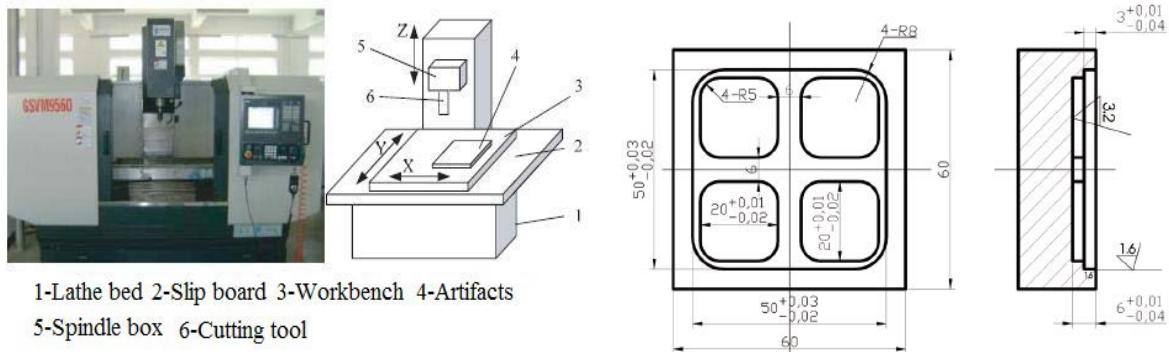

Figure 2: Schematic diagram of NC milling

3.3 The application of NC turning technology

CNC turning technology is one of the most common CNC machining method, it is a relatively mature technology, such as shaft guide column, stamping die punch, shaft parts, forging die plate part, injection mold, etc. CNC turning technology not only improves the machining accuracy and quality, but also increases the range of processing different parts. So, it can be used for different types of parts processing. CNC turning technology is the basis of the entire manufacturing industry. CNC lathe can only be used in the processing of some parts of the mold. Under normal circumstances, CNC turning technology is mainly used in rod and rotary mold processing. Rod parts are mainly guide posts, the top and so on. Rotary parts are mainly stamping die punch, disk and shaft parts forging die, basin and bottle injection mold. The schematic diagram of NC turning machining is shown as the Figure 3.

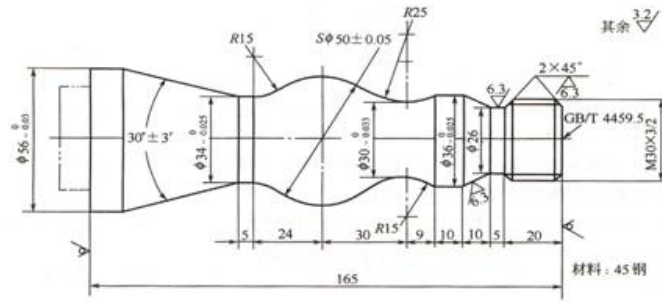

Figure 3: Schematic diagram of NC turning

4. Conclusion

In view of the application on digital control machining technology, flexibility and intelligence will be the future development direction of NC technology. Compared with the traditional processing technology, CNC manufacturing technology has incomparable advantages. CNC mechanical mold manufacturing can not only improve the precision and quality, but also reduce labor intensity. More importantly, it can bring certain economic benefits to enterprises, which is greatful for promoting the mold manufacturing industry development.

References

- [1] Wang sheng. Research on mold manufacturing and CNC machining technology [J].Shandong industrial technology, 2016, 02:24.
- [2] Lin chaoyang. Technical analysis of CNC machining and manufacturing of mechanical molds [J]. Rubber and plastics technology and equipment, 2016, 10:108-109 + 119.
- [3] Wu weifeng. Research on mold manufacturing and CNC machining technology [J].Digital technology and applications, 2013, 05:26.
- [4] Shen yuchen. CNC machining and manufacturing technology of mechanical molds [J]. Modern manufacturing technology and equipment, 2017 (24): 178-179.